



# **Transient Stability Analysis**

*by*

**Mr. Santoshkumar M. Hunachal**

**MAHARSHI PARSHURAM COLLEGE OF ENGINEERING,  
VELNESHWAR**

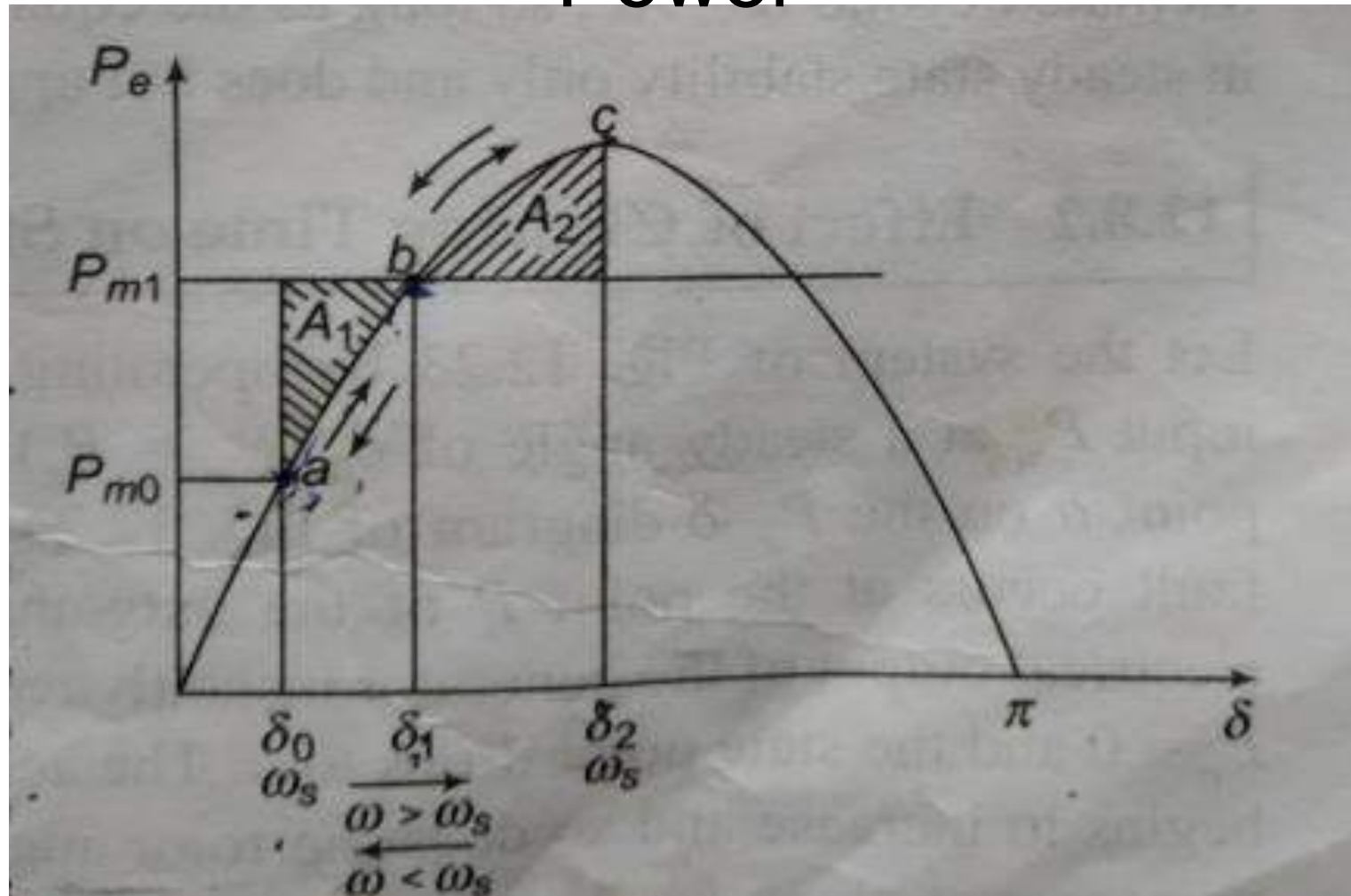


# Transient Stability

Equal Area Criteria Applications;

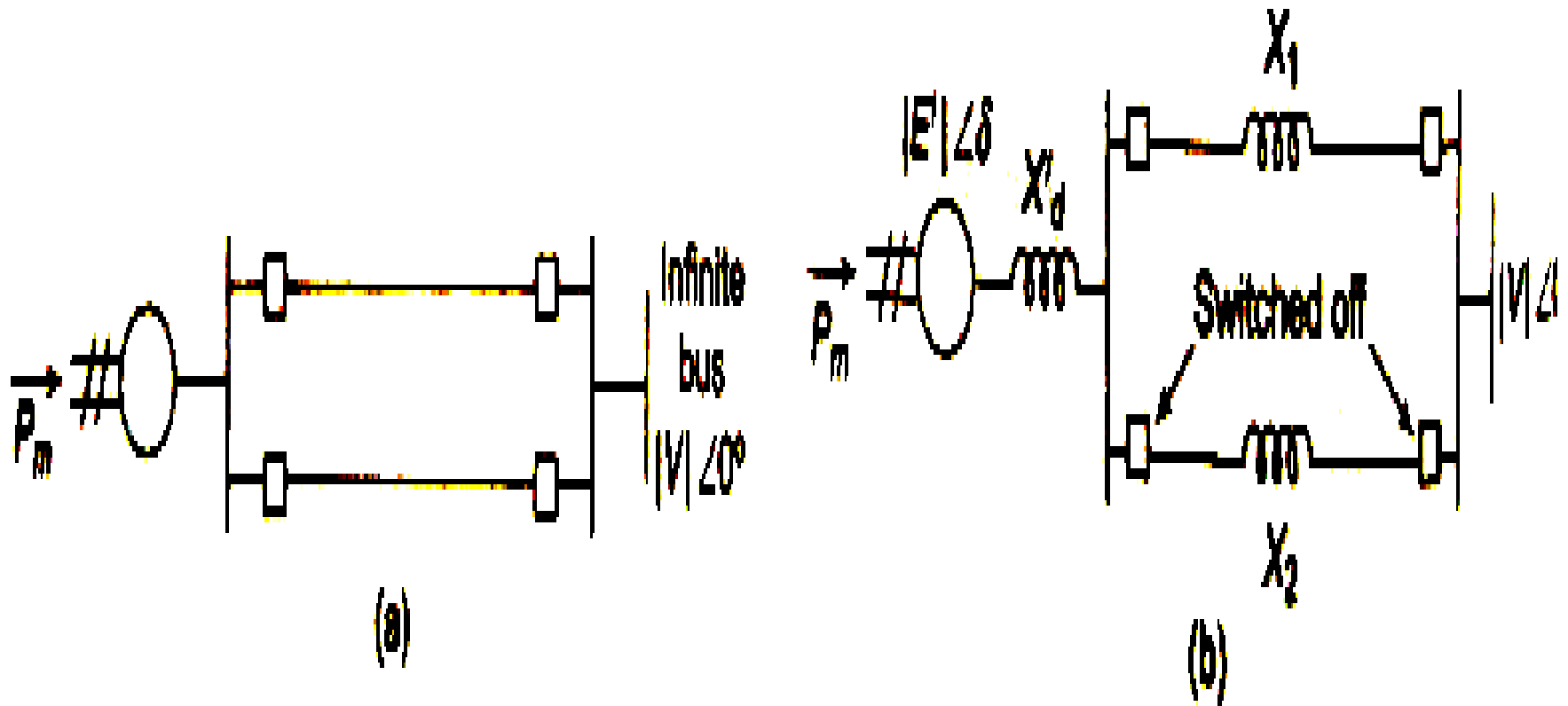
1. Sudden change in Mechanical Input Power
2. Sudden loss of one of parallel lines
3. Sudden Short Circuit one of parallel lines
  - 3.A. Case a: Short circuit at one end of line
  - 3.B. Case b: Short circuit at away from line ends

# 1. Sudden change in Mechanical Input Power

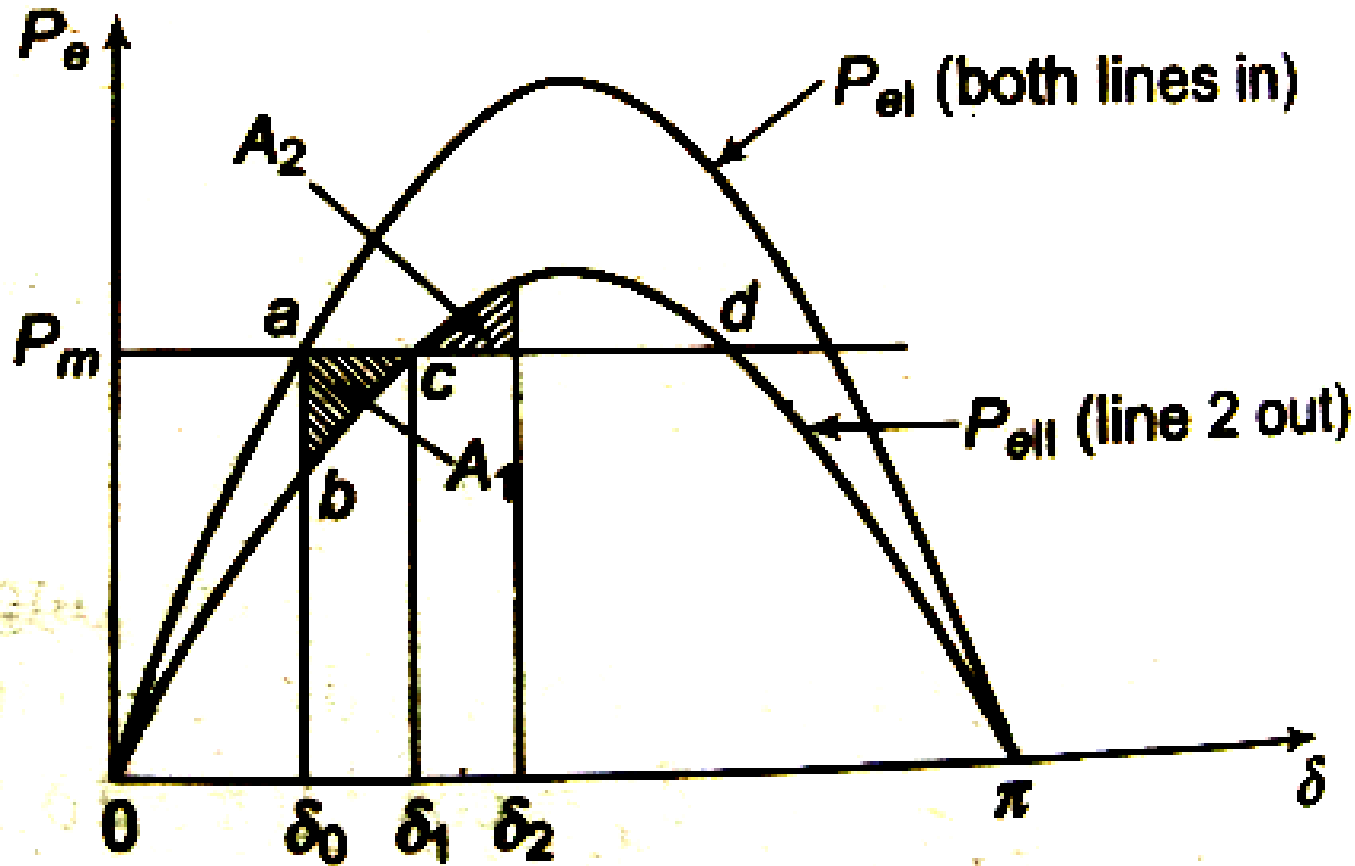


**Equal Area criterion applied to sudden increase in mechanical input to generator**

## 2. Sudden loss of one of parallel lines

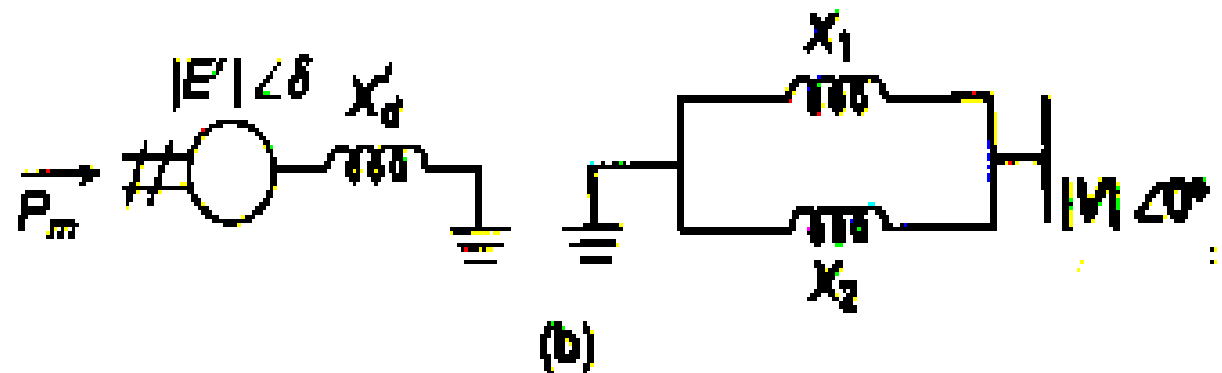
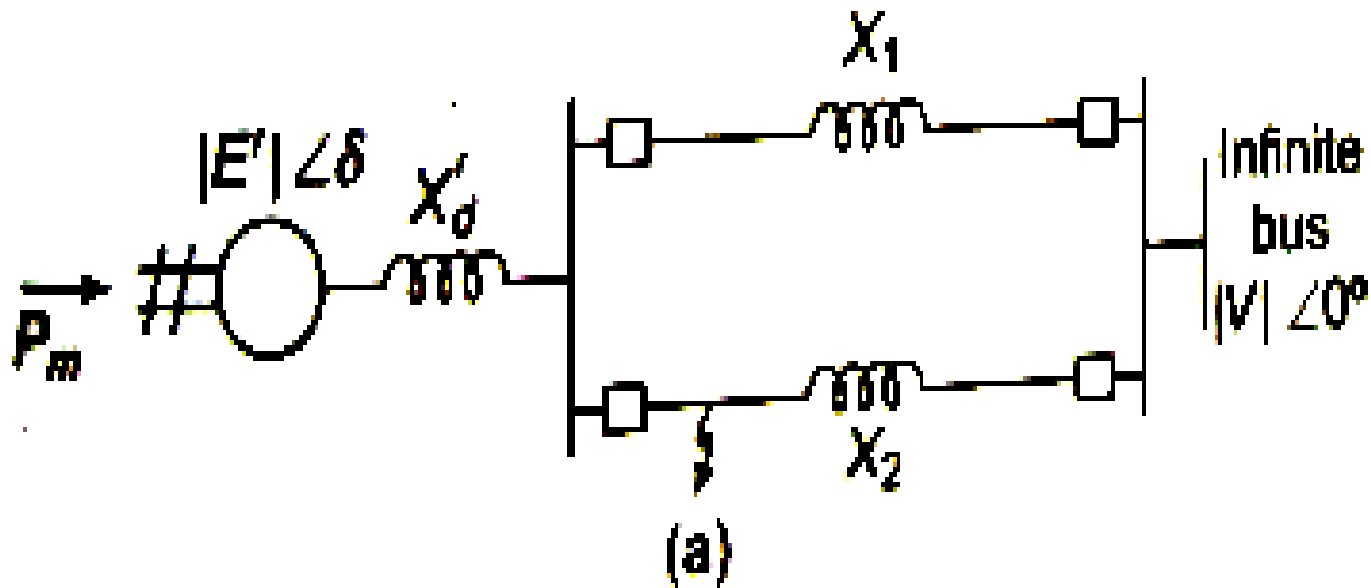


**Fig.2: Single machine tied to infinite bus bar**



Equal Area criterion applied to opening of one of the two lines in parallel

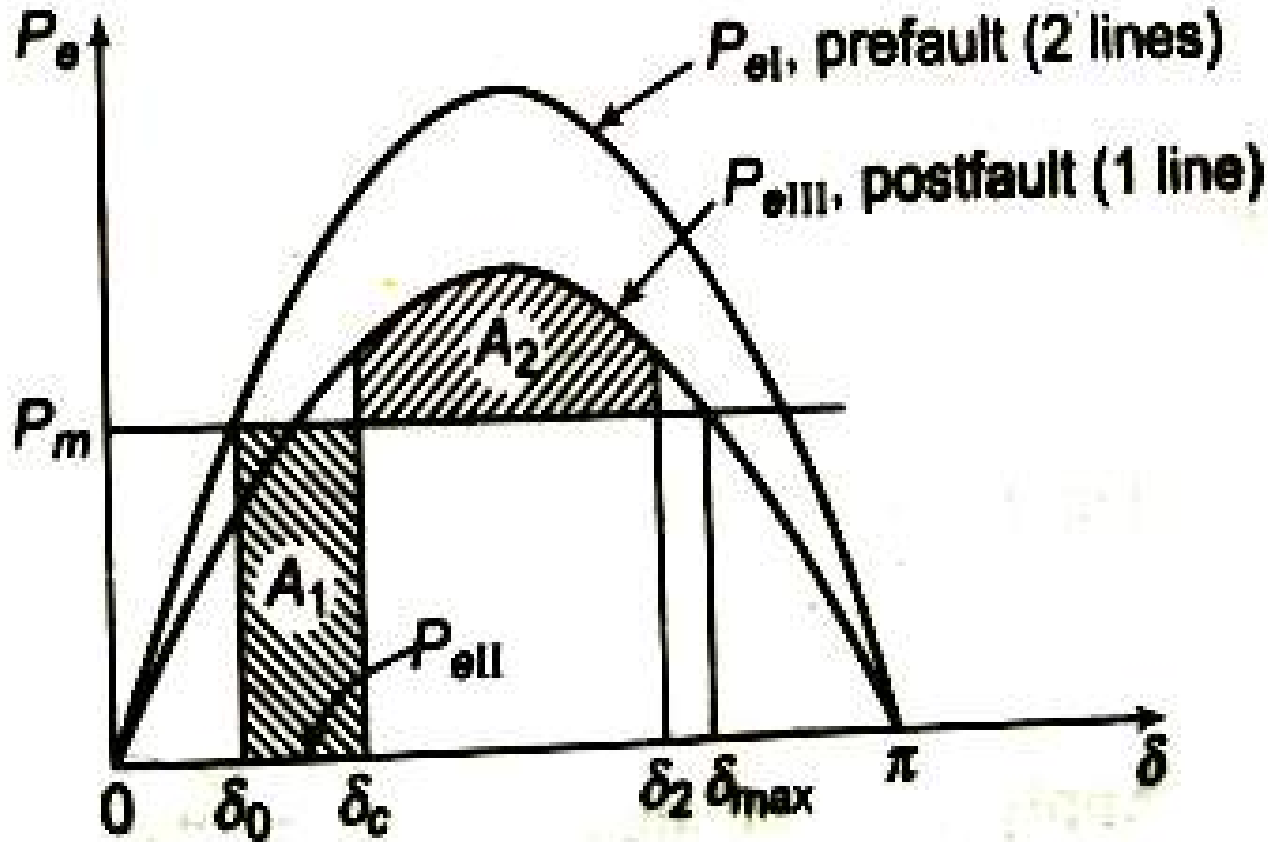
### 3. Sudden Short Circuit one of parallel lines



Case a: Short circuit at one end of line

# Equal Area criterion applied to Short Circuit one of parallel lines

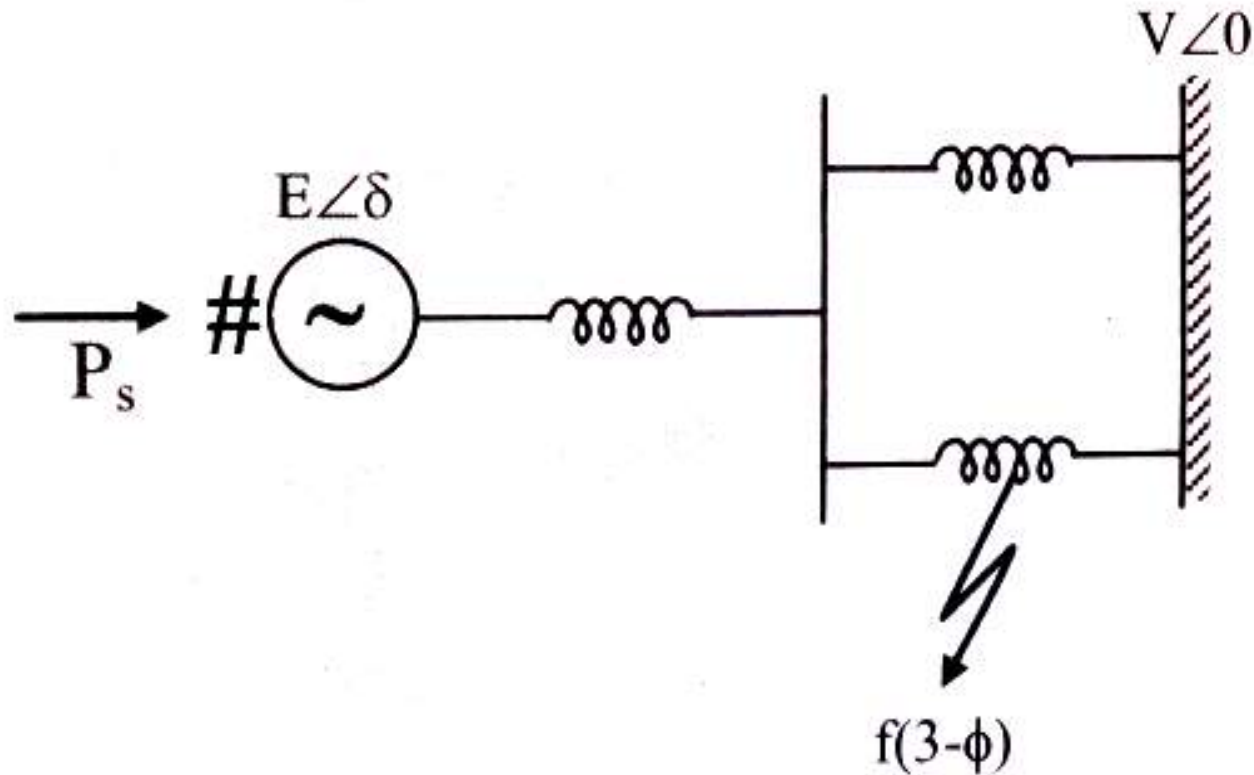
## Case a: Short circuit at one end of line



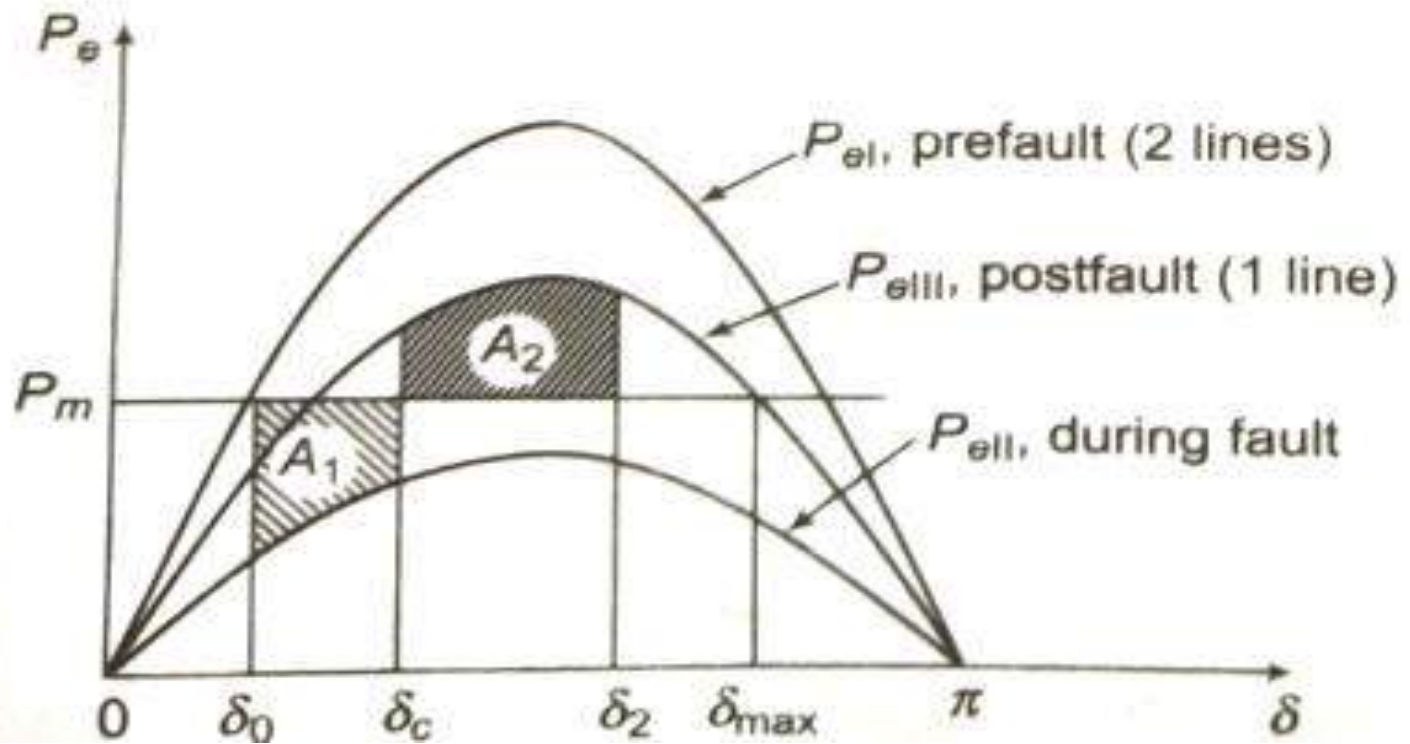
I. System normal, II. Fault applied, III. faulted line isolated

# Equal Area criterion applied to Short Circuit one of parallel lines

## Case b: Short circuit at away from line ends







EAC applied fault on middle of tr. Line:

**Thank You**